



23 Elm St., Peterborough, NH 03458  
Tel: (800) 543-3458 (603) 924-9481  
Fax: (603) 924-9482  
Web site: www.cimindustries.com

CIM IG-6  
11/06

## **Instruction Guide APPLICATION OF BLACK CIM TO EARTHEN PONDS AND RESERVOIRS (USING CIM SCRIM)**

### **1.0 DESCRIPTION**

This guide covers the installation of a black CIM Coating over Scrim for lining earthen ponds and reservoirs. The system shall consist of a minimum of 60 wet mils (see product Coating Profile for appropriate coverage chart) applied by spray equipment. See C.I.M. Industries Instruction Guide “Spray Application Guide” (IG-12) for more information on spraying black CIM Coatings.

### **2.0 MATERIALS**

#### **2.1 CIM Premix & Activator**

#### **2.2 CIM Scrim**

#### **2.3 Optional Materials**

##### **2.3a. CIM 1000 Trowel Grade Premix & Activator**

##### **2.3b. CIM Bonding Agent**

### **3.0 SAFE PRACTICES**

Use equipment and procedures designed to minimize danger to personnel and materials. Special attention should be made to provide adequate ventilation and respirators for personnel applying black CIM systems in confined spaces or operating spray equipment. See C.I.M. Industries “Applying CIM Within Confined Space Applications” (IG-9) for more detailed information.

### **4.0 SURFACE PREPARATION**

All areas adjacent to those being coated with black CIM products which are not intended to be coated should be protected with suitable temporary splash covers such as polyethylene, carpenters paper, or masking tape.

#### **4.1 Construction of the Basin**

The basin may be excavated by any convenient means. Excavated soil is graded into a compacted embankment. All surfaces of the basin shall be tightly compacted, smooth, and free of holes, rocks, stumps, debris or sharp protrusions of any sort. The finished liner is anchored by backfill in a trench excavated around the perimeter of the embankment (see Figure 1).

#### **4.2 Limitations on the Slope of Sides**

The slope of the sides will vary with site conditions and shall be determined according to good engineering practice after due consideration of the type of soil, the intended use of the basin, the risk of danger in case of collapse, etc.

**Figure No. 1  
CIM Pond Liner Details**

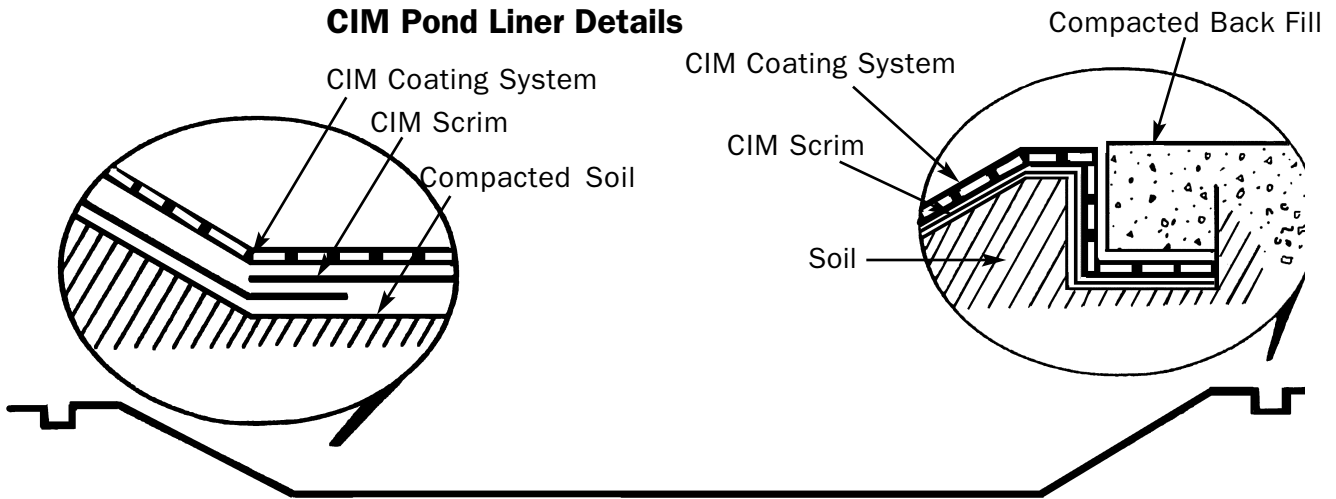

**NOTES:**

**4.3 Venting**

Elastomeric pond linings can be damaged or ruptured by gas pressure created beneath them. Gas formation is common in certain oil and gas producing areas and can occur anywhere organic materials are present in the soil beneath the black CIM coating.

Landfill caps require especially careful engineering site work to allow for possible gas formation in the materials beneath the liner. The decomposition of the organic materials present in existing landfills can produce very significant quantities of gas. Provision for proper venting at the time of basin construction is critical.

In areas where both marsh lands and oil deposits are found, such as Gulf Coast locations, gas-producing mechanisms also tend to be highly active. Accordingly, such areas should be carefully surveyed to determine whether this situation exists before the basin is constructed. If continuous gas evolution is suspected, the reservoir should be built with a bottom slope, opposed to a flat bottom, and sloped underdrains (French drains or perforated pipe) should be used to vent gases that form below the black CIM coating. Locations with a lot of sandy soil or gravel may not be a concern because they are porous enough to naturally vent gases. Refer to Figure 2 for a representative vent detail. Other appropriate vent designs may alternatively be used, but care must be taken to ensure a similarly good seal to the black CIM coating.

**NOTES:**

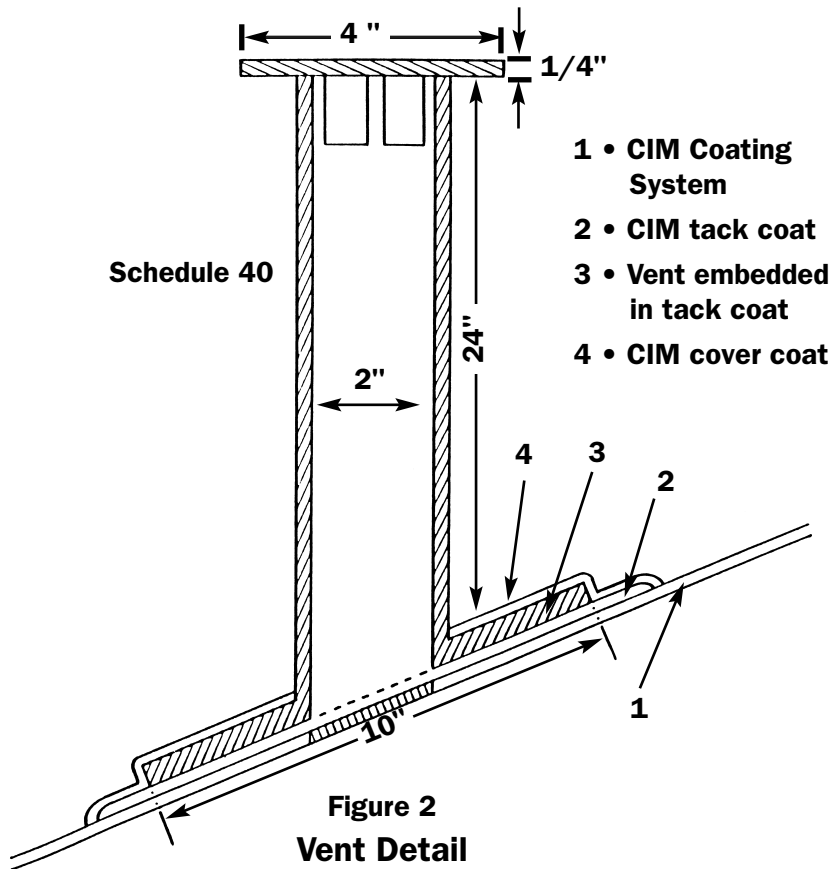

**4.4 Specification of CIM Scrim**

It is recommended to use CIM Scrim for earthen systems. CIM Scrim is a stitch bonded polyester fabric packaged in 100 yard roll lengths. The fabric is used to cover earthen substrates to prevent black CIM Coatings from seeping into the ground, thereby using much more product than necessary to create an effective liner. CIM Scrim is available in 100 yard long rolls with widths of 6", 12", 40", and 120". Other fabrics may also be used, but should be tested for compatibility.

**4.5 Placement of the CIM Scrim**

CIM Scrim shall be placed over the entire surface of the basin using a six (6) inch (15 cm) overlap on all longitudinal and transverse joints. Refer to Figure 1 for a detailed depiction of an overlapped joint. Particular attention should be paid to fitting the lining with a full six

---

**NOTES:**

inch overlap along the bottom of any sloped walls where they meet the bottom of the basin, as detailed in Figure 1. The liner installer should pay heed to climatological conditions, since placement of the CIM Scrim should include provisions for overlaps not to oppose prevailing winds. Weights (sandbags, used tires, containers, etc.) may be required to contain CIM Scrim and keep it in place during construction.

The CIM Scrim shall extend over the outside edge of the basin into, and across the bottom of a perimeter trench excavated to a minimum depth of one (1) foot (30 cm) as depicted in Figure 1. After construction of the black CIM liner system is completed, the perimeter trench shall be backfilled and compacted thoroughly.

The CIM Scrim shall be cut to fit each corner so that no area shall have more than three (3) layers. There shall be no air pockets under the fabric and no bulky areas with too many layers.

## **5.0 APPLICATION**

### **5.1 Penetrations and Other Non Soil Substrates**

Black CIM coatings will adhere to most clean construction materials. When coating substrates, please see the C.I.M. Industries' specific substrate Instruction Guide for detailed information of application procedures.

### **5.2 Quantity Applied**

Black CIM coating systems must be spray applied to CIM Scrim over earth and must be applied at a thickness of at least 60 wet mils. See C.I.M. Industries' Instruction Guide "Spray Application of CIM" (IG-12). The CIM Scrim will absorb most of this amount, creating a waterproof system. Apply sufficient black CIM product so that the fabric is no longer visible in order to assure that the black CIM product is at least 60 wet mils. The finished section should appear shiny, not dull, indicating that the fabric is fully saturated.

---

**NOTES:**

Concrete trench areas, inflow and outflow structures and equipment pads within ponds and reservoirs must also be coated with at least 60 wet mils of black CIM. Refer to the appropriate instruction guide for applying black CIM products to substrates other than soil.

**5.3 Horizontal and Sloped Surfaces**

Black CIM coatings should be applied to CIM Scrim at a wet film thickness of 60 wet mils or more, depending on application type. This can be achieved in a single coat on horizontal and multiple coats on sloped surfaces.

**5.4 Vertical and Near-Vertical Surfaces (non-earthen)**

Vertical and near-vertical surfaces can be coated by spraying or rolling. Small walls may be coated with rollers or brushes; large walls should be sprayed with an air assisted airless spray system or plural component spray system. See C.I.M. Industries' Instruction Guide "Spray Application of CIM" (IG-12) or contact C.I.M. Industries for suggested equipment configuration. Black CIM products will require a minimum of two coats of approximately 30 mils each, to obtain the required 60 mils on these surfaces. If more than 60 wet mils is specified on a vertical or near-vertical surface, additional coats will be required. Subsequent coats are performed after the previous pass becomes tack free. The first pass becomes tack free typically 1-4 hours after mixing for any black CIM coating product. See section 5.5, Multiple Coats for further instruction.

**5.5 Multiple Coats**

Second/multiple coats can be applied as soon as the previous coat can be touched lightly without coming off on your finger. For black CIM products at 70°F, the tack free time is typically one (1) hour but no longer than four (4) hours after the previous coat has been applied. Higher temperatures speed up the curing time, and tack free time, therefore significantly shortening the 1-4 hour recoat window. Colder temperatures have the opposite effect. As soon as the coating becomes tack free, the second coat should be applied. For immersion or traffic service, apply all coats within the recoat window except at joint lines.

If second/multiple coats cannot be applied within the recoat window (1-4 hours under standard conditions), the previous coat must be abraded. Abrading shall be performed by surface grinder or other mechanical means. The black CIM must be solvent wiped (MEK or xylene) to clean up any loose debris. After the solvent flashes off, a

---

**NOTES:**

light mist of CIM Bonding Agent must be applied. Allow the Bonding Agent to flash off and recoat within one (1) hour. For immersion or traffic service, minimize areas to be recoated outside the recoat window, severely abrade the areas to be recoated and test recoated areas for acceptable adhesion. Acceptable adhesion may only be achieved through aggressive abrading.

**5.7 Overlap at the Joints**

If work cannot be completed in a single day, a minimum of approximately two (2) feet (60 cm) of fabric shall be left uncoated to form a joint for the next day's work. Whenever the liner has cured for longer than the specified recoat window (four (4) hours for black CIM products), the last six (6) inches of the coating should be prepared as described in Section 5.6, Recoating After the Recoat Window.

**5.8 Backfilling**

After the liner has cured, all perimeter trenches into which the liner extends shall be backfilled and compacted (See Figure 1).

**5.9 Protecting CIM Using a Cover Material**

Black CIM coating systems, applied over a properly compacted base, are suitable for light to medium duty applications, such as lining ponds subject to occasional foot traffic or occasional light vehicle traffic.

A cover material is necessary for heavier duty applications, such as ponds subject to hooved animals. Cover the cured liner with a minimum of one (1) foot (30 cm) of sand, soil, or gravel to a necessary depth.

If the pond, basin or reservoir is to be dredged or "harvested" using mechanical equipment, a minimum of two (2) feet (60 cm) of cover shall be placed over the black CIM coating. The cover material should consist of two (2) layers of distinctly different characteristics (size, color, texture) so the operator of the harvesting equipment will realize how close to the coating he is operating. This will reduce the risk of damage to the coating.

**5.10 Safety Mechanisms**

Ponds and reservoirs large enough to swim in, and deep enough to drown in, should be constructed with safety mechanisms. Most coatings become slippery when wet, making it difficult to climb out. If someone accidentally falls in, or decides to go for a swim, they may not be able to get out of the pond.

---

**NOTES:**

Fences are typically used to keep people out of a designated area. Chain link fences should be placed around ponds and reservoirs not meant for swimming. Fences can also be used to get people out of a designated area. A chain link fence can be rolled into a constructed pond and anchored at the top of of the pond. This provides a mechanism for exiting a pond with low water levels should someone happen to fall in or go for a swim.

Non-skid surfaces can also be created, as an alternative to chain link fences, by broadcasting aggregates into a wet tack coat. See C.I.M. Industries' "Topcoats" (IG-7) for more detailed information on creating non-skid surfaces.

## **6.0 TOPPINGS**

The black CIM system may include toppings of aggregate, decorative coatings, protective coatings, or combinations of the above. See C.I.M. Industries' "Topcoat Application Guide " (IG-7) for more detailed information.

## **7.0 GENERAL LIMITATIONS**

Applying any black CIM product under any of the following conditions is likely to result in poor or unsatisfactory performance:

- Use of improper mixing equipment. See C.I.M. Industries' Instruction Guide, "Mixing CIM Premix and Activator" (IG-8).
- Material temperature at the time of application is below 60°F.
- Use of standard application procedures when substrate temperature is below 50°F. See C.I.M. Industries' Instruction Guide "Applying CIM Coatings in Cold Weather" (IG-11).
- Substrate moisture is present or rain is imminent.
- Substrate temperature is less than 5°F above the dew point.
- Substrate within pond is in a temperature-rising mode/exposed to direct sunlight.
- Other conditions which are obviously unsuitable.

